



Australian Jugger League

How to #1 : Making Jugger Weapons

Prepared by: Tony of the Melbourne Jugger League

Making Juggler Weapons

Materials

- 25mm PVC
 - 20mm PVC
 - Pool Noodles or Pipe Insulation
 - Open Cell Foam or Camping Mattress
 - Duct Tape
 - Hack Saw
 - Sharp Knife
 - Tape Measure
 - Permanent Marker
-

Material Descriptions

PVC Pipe - PVC pipe is a plastic pipe that is used in plumbing. It's lightweight and easy to work with and make the structure of the Juggler weapon. You can buy it at hardware stores such as Bunnings or Mitre 10 or plumbing supply places such as Reece or Tradelink. You can use 20mm pipe for Short Weapons and 25mm sleeved with 20mm for Two Handed Weapons. There are different types of this pipe but it is recommended to use high-pressure pipe that is marked with PN18. There is orange pipe with black lettering but it is only used on shorter weapons.

Pool Noodles - These foam tubes are used as pool toys. They are used for padding the PVC pipe. They are available at most large super markets during the summer (Target, Reject Shop, Coles). As a seasonal item, most places will only stock them in the summer. Some pool stores and Clark Rubber stocks them year-round but can be more expensive. Pool Noodles come in 1500mm rods from \$2.00 to \$7.00 each. You'll want to buy pool noodles that have an inner hole equal to the size of the PVC pipe (about 25mm but a 20mm hole will fit).

NB. *Because of the nature of the material pool noodles are made from the foam compresses over time. It is a good idea to regularly check anything you make using this material (every few games) to make sure that the core is still sufficiently padded.*

Pipe Insulation - For the pipe insulation rubber we use plumbing supply or refrigeration places like Reece or Heatcraft who sell rubber pipe insulation in 2 metre length tubes. You want a rubber with a wall thickness of at least 19mm.

NB. Pipe insulation is the preferred padding method as it is more durable and will not compress as easily.

Duct or Cloth Tape - You can get this at just about any store with a home improvement section. It's used to wrap around the padding to keep it in place and prevent premature damage. There are many grades and colours of duct or cloth tape. Cheap tape is usually cheap in quality. Look to spend about \$2.00 a roll for cheap tape and up to \$15.00 a roll for very good tape. One roll should yield about 2-3 weapons.

Hack Saw - These saws are very common and can be found at any hardware store. It makes an ideal cutting tool for both the PVC pipe and the pool noodle..

Tape Measure - You'll only need a small tape measure, 5 metres is plenty.

Permanent Marker - You'll need it for marking measurements for cutting, so get one with a broad tip. Make sure the marker will work well on plastic. If it easily wipes off it's no good to you.

How to Build the Weapons

Step 1

Using the measuring tape and the permanent marker, measure off the appropriate length of PVC pipe. Then measure off the appropriate lengths of padding. See table and diagrams below.

Weapon Type	Overall Length	PVC Length	Padding Length/s	PVC Pipe Used
Staff	1800mm	1650mm	1000mm + 250mm + 100mm	25mm + 20mm
Q-Tip	1800mm	1600mm	500mm + 500mm + 200mm	25mm + 20mm
Long Sword	1500mm	1350mm	1100mm + 100mm	25mm + 20mm
Short Sword	750mm	500mm	500mm + 100mm	25mm

Cross Section of Weapon

Two Handed Weapons

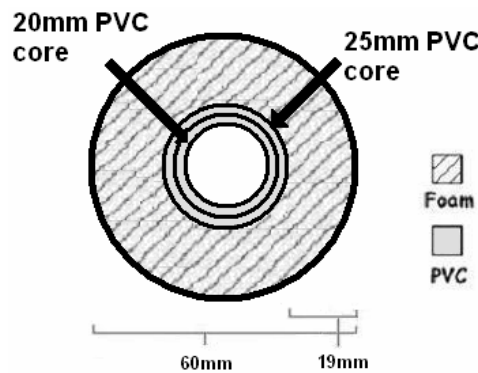

One Handed Weapons

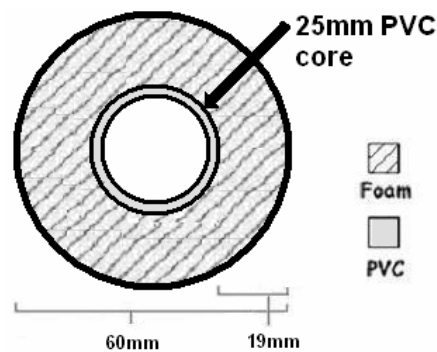

Staff

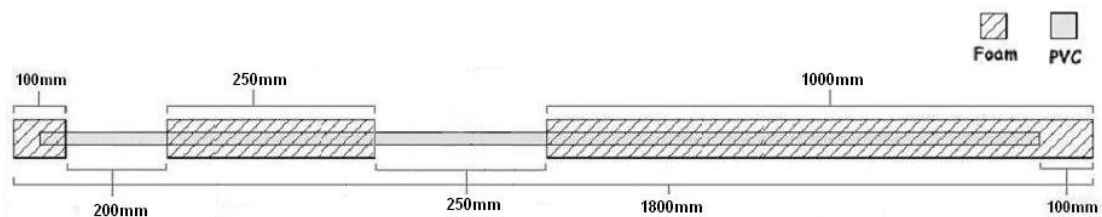

Q-Tip

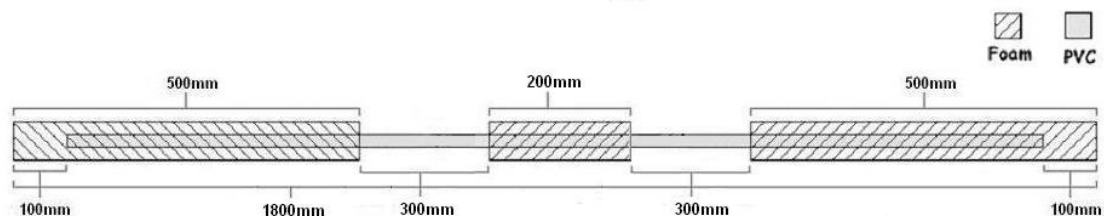

Long Sword

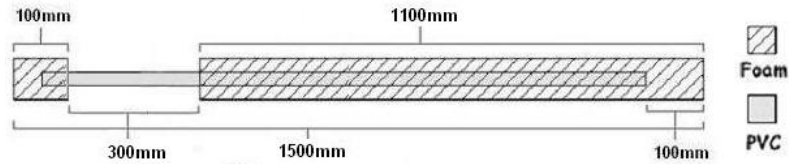

Short Sword

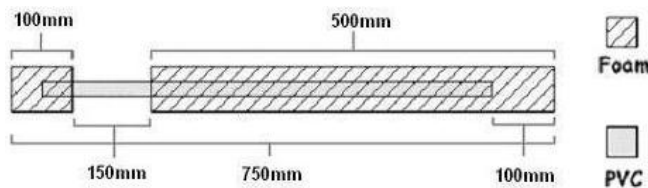

Step 2

Use the hacksaw to cut both the PVC pipe and the padding at their marked lines. Two Handed Weapons must be 25mm pipe sleeved with 20mm pipe for extra strength. This is done by wrapping the 20mm pipe with tape so that it fits tightly into the 25mm pipe.

Step 3

Feed the PVC pipe inside the piece of padding until the tip of the pipe is 100mm from the end of the padding to give you 100mm of padding at the tip of the weapon. It's important to leave 100mm or padding because if the weapon is thrust into an opponent, it must compact enough not to hurt. See *below Thrusting Tips* for making softer thrusting tips.

For the Q-Tip feed the other length of padding onto the other end in the same way making sure to leave 100mm gap at the end.

Note: Sometimes the hole in the padding is very tight on the PVC. You can work the padding onto the PVC pipe by twisting the padding slowly over the PVC pipe. Be careful not to let the pipe cut the inside of the padding.

Step 4

For the Staff, Long Sword and Short Sword, measure 50mm on the exposed end of the PVC pipe, and thread the 100mm piece of padding on it. This leaves 50mm of padding on the pommel. This section is padded because you sometimes hit people (or yourself) with the pommel. Then take some spare foam (Open Cell or Camping Mattress) and stuff it inside the cavity at the ends of the weapons and secure it down with tape.

Step 5

Cut the end of the padding where it meets the handgrip on a 45 degree angle to make taping the padding to the core easier.

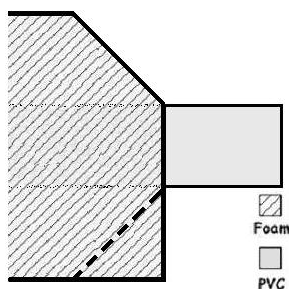

Step 6

A layer of tape now needs to be stuck over the padding. This is done because the padding will slowly slip off if it's not secured and the padding is easily damaged without a protective layer.

Taping is done length wise up the blade to prevent compressing the foam, which can happen if you wrap the tape around the blade.

Pull 75mm of tape off the roll, but do not cut it yet. Start the tape on the handle 75mm from the blade, and run it up the length of the blade, pulling off more tape as you go, until you reach the tip.

Cut the tape so that it sticks halfway over the end of the tip. It's important that you don't compact the padding when you tape the tip.

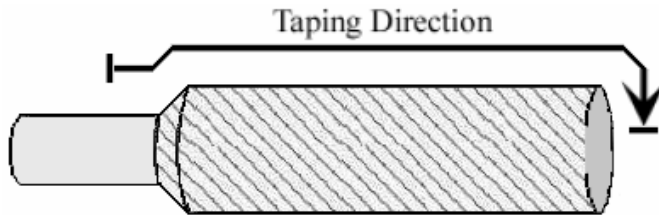

Start another length of tape at the handle, so it's over-lapping the first strip of tape by about 5mm. Repeat the previous step.

Secure the tape to the handle.

After the blade is fully covered, you'll notice the tape at the handle will want to come loose. Use a small piece of tape and wrap it around the tape on the handle to keep the tape tight.

Step 7

Follow the same taping technique to tape the other padding to the weapon.

Step 8

Cover the handle with a tape to cover the PVC pipe if you want.

The padding will wear down with continued use, and will eventually break. It is always a good idea to check you weapons before using them.

Thrusting Tips

Thrusting tips are a means of making a weapon safer. A standard generic weapon has 100mm of empty padding at the tip. For most users this is safe enough to not have to worry about injury, but for newer players this can still be a bit hard to get stabbed by. Thrusting tips add open cell foam to the tip making it much softer.

When adding a thrusting tip to a weapon you only need about 25mm of padding past the end of the PVC core, you will add an extra 75mm. Be sure to put a few layers of tape over the end before applying the thrusting tip.

To make the thrusting tip take a 75mm cube of open cell foam. Cut the cube into a cylinder that will line up to the end of your weapon tip. You attach it to your weapon by when you start taping it up. Be sure not to compress the foam when you're taping over it. You want it to be nice and spongy when you're done. Poke some small holes in the area where the thrusting tip so it will compress better.

Making Chain Weapons

Materials

- 2.5 metres of plastic garden chain
- Open cell foam block or ball (30cm minimum Diameter Cube or Ball)
- 2 to 6 metres of rope
- 50cm of Pipe Insulation (25mm x 19mm)
- Duct Tape
- Hack Saw
- Sharp Knife
- Permanent Marker

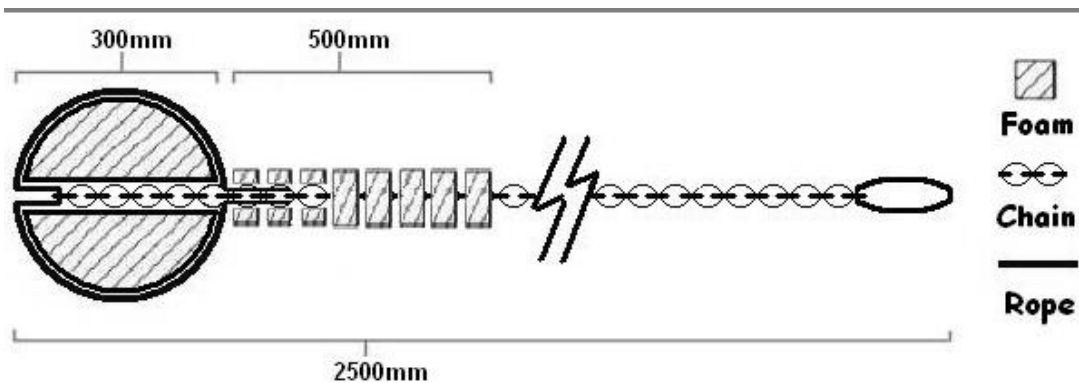

Step 1

Drill a hole through the centre of the piece of foam. Cut the plastic chain to length.

Step 2

Find the middle of the piece of rope and feed the middle through the hole in the foam

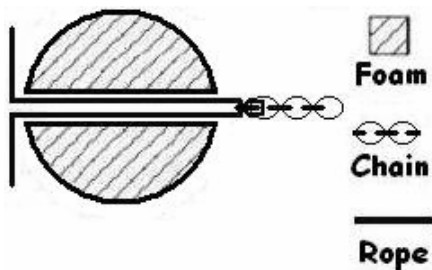

Step 3

Loop the middle of the rope through the first three links of the chain and pull the chain back on itself to secure the rope to the chain.

Step 4

Pull on the other end of the rope to pull the chain until it is approximately halfway inside the piece of foam.

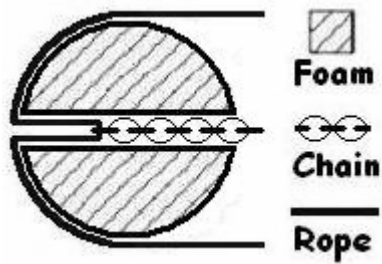

Step 5

Loop the rope around the ball and tie the rope back on to the chain through a couple of links to make sure that the ball is attached to the chain securely; this is when using a shorter length of rope.

With a longer piece of rope, after you tie the rope back onto the chain, feed the rest of the rope through the rest of the links (this will add some weight to the overall weapon but will make the chain itself safer and more durable since if the links break parts will not go flying off and you are less likely to get you fingers caught in the links).

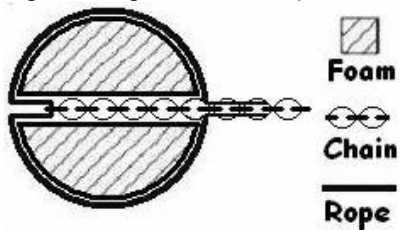

Step 6

Cover the ball with lightly with duct tape so as not to compress the foam. Another option is to cover the ball with cloth material.

Step 8

Add some piping insulation cut into 50mm lengths to the first 50cm of links on the chain, since this is the part that will most often strike a person and this adds more safety and padding to the chain.

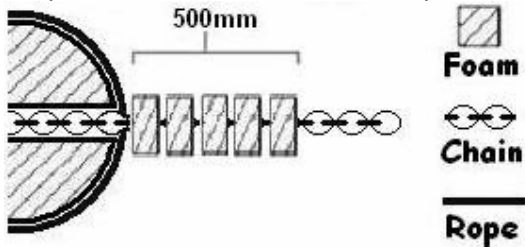

Making Shields

Materials

- 10-12mm Plywood
 - Open cell foam 750mm X 750mm X 75mm
 - Pipe Insulation
 - Duct Tape
 - Jigsaw
 - Sharp Knife
 - Permanent Marker
 - 40mm wide Leather Straps or Seat Belt Material for arm straps
-

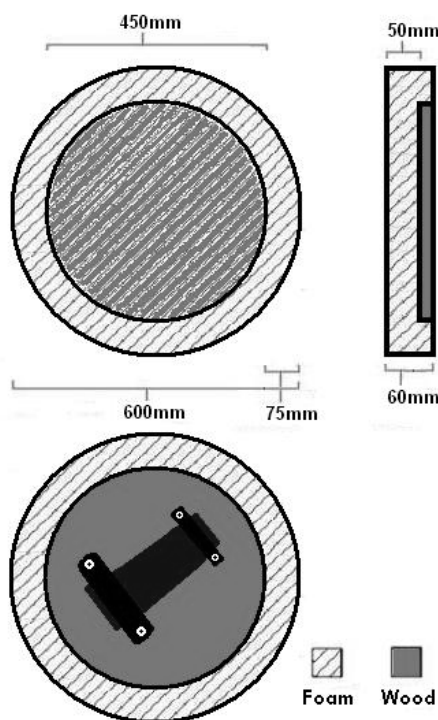

Step 1

Mark out the shape of the shield, making it approximately 150mm less in diameter to allow for padding. **Shields with sharp angles and corners are to be avoided due to possible injury to yourself or other players.**

Step 2

Cut out the shield. Clean up the edges with a file or sander.

Step 3

Lay your arm on the shield in the position you are most likely to carry the shield. Use the marker to make 4 dots one on each side of your palm and one on each side of the THICKEST part of your forearm.

Step 4

Drill holes for the wrist and arm straps about 30mm farther out than the points you marked

Step 5

Drill or cut holes in the ends of the two leather strips. Try to center the holes.

Step 6

Fasten the straps to the backing. Bolt, washer, plywood, strap, washer then nut. The washers are very important as they keep the backing from pulling through the plywood and keep the leather from tearing. Cover the nuts and blot ends with foam and tape so that you don't injure yourself on them.

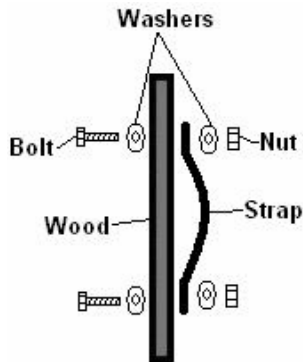

Step 7

Set the wood on top of the foam. Use your marker to trace a line around the edge. Redraw another circle 75mm radius larger than the first circle. Cut the foam out along the line you have just drawn using a sharp knife, hacksaw or large pair scissors. An electric knife also does the job quite nicely. Don't worry about it being perfect. The cover will obscure any distortions.

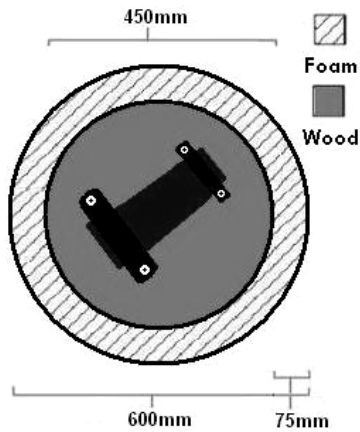

Step 8

Cut out a section of the foam so that the plywood sits flush into the foam. Now glue the plywood to the foam.

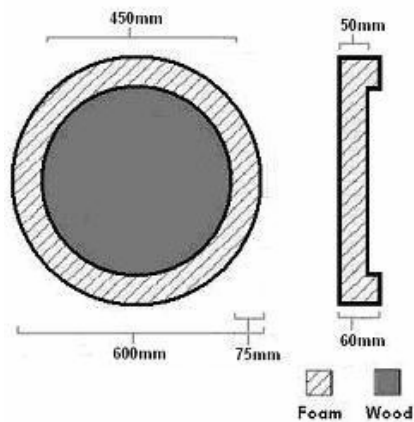

Step 9

Now put a cover on the shield. This can be done with tape or cloth. It is recommended that shield have a layer of foam on the back.

Testing Gear

This is probably the most important thing you can do after making your gear, don't allow anything on to the field that has not been tested for safety or that most people are not willing to face.

For staves and swords the testing is simple take your completed weapon over to some hard surface and hit it end on, if you can hear the core hitting the surface then the end is not padded enough.

The second part is a little more fun, use it on some people - generally start on the person that made it and a couple of other people. If you are not fine being hit with it you may need more padding.